

Size: 2"-12"

Rising Stem, Bolted Bonnet, Solid Wedge Disc, Flange Type

Design Std: DIN3356

Face to Face: DIN3202 F1

Flange Drilling: DIN2531, DIN2532, DIN2533

Other flange drilling special, is available on customers' request.

The valve is closed by turning the stem in clockwise direction. Underground installation set available on request.

Gear Box Operator or Wrench Head is available on customers' Requirement.

Application Specification

Size (DN)	Pressure Rating (PN)	Hydro-Test Prssure		Suitable Medium
		Body	Seat	
15-200	16	2.4 Mpa	1.6 MPa	Water, Oil, Steam
15-300	10	1.5 MPa	1.0 MPa	

Materials List

No	Part Name	Materials	
1	Body	ASTM A126A(B)	GG20 GG25
2	Disc	ASTM A126A(B)	GG20 GG25
3	Bonnet Gasket	Graphit	Graphit
4	Double-screw Bolt	A216 WCB	GS-C25
5	Gland	ASTM A126A(B)	GG20 GG25
6	Double-screw Bolt	A216 WCB	GS-C25
7	Washer	A216 WCB	GS-C25
8	Nut	A216 WCB	GS-C25
9	Handwheel	ASTM A126A(B)	GG20 GG25
10	Yoke Nut	ASTM B36	Brass
11	Bonnet	ASTM A126A(B)	GG20 GG25
12	Stem	ss410	X10Cr13
13	Washer	A216 WCB	GS-C25
14	Packing	Graphit	Graphit

Dimensions List (Flange conform to DIN2533)

DN	D	D1	D2	L	H	b	n	d
15	95	65	45	130	180	12	4	14
20	105	75	58	150	180	14	4	14
25	115	85	68	160	207	14	4	14
32	140	100	78	180	218	16	4	18
40	150	110	88	200	246	15	4	18
50	165	125	102	230	290	17	4	18
65	185	145	122	290	320	17	4	18
80	200	160	138	310	350	19	8	18
100	220	180	158	350	380	21	8	18
125	250	210	188	400	530	23	8	18
150	285	240	212	480	430	23	8	23
200	340	295	268	600	630	27	12	23
250	405	355	320	730	720	29	12	27
300	460	410	378	850	840	29	12	27

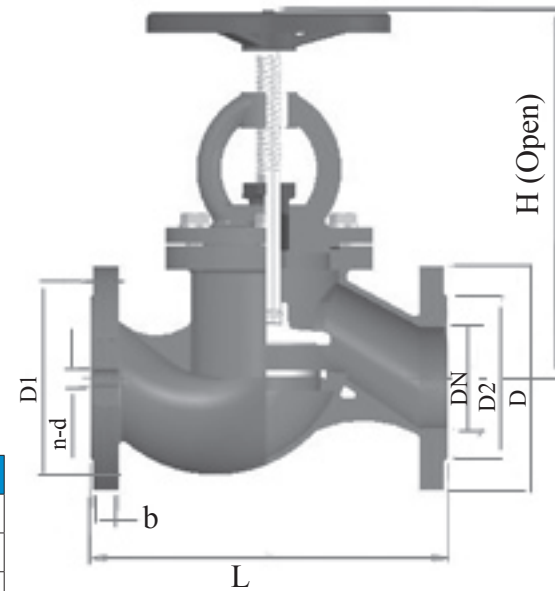
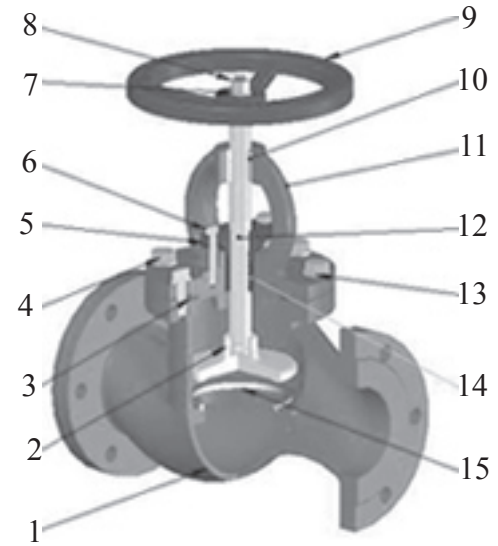

When placing the order, please specify Working Pressure, Working Temperature, Flange Drilling Etc;